



TECHNICAL BROCHURE

B5-75GSX

GS-CBM GS Xtreme™

60 HZ, 4" SUBMERSIBLE PUMPS

 **GOULDS**
WATER TECHNOLOGY
a xylem brand

Residential Water Systems

FEATURES

Field Proven Design: The GS Xtreme features super strong construction due to the welded casing joints at both ends. The proprietary engineered polymer bearings have been field proven with great success in some of the toughest submersible pump applications on the planet - coalbed methane extraction. They are the deepest set pumps we build, available up to 10 HP in many models. Capable of pumping over 1600' TDH.

Powered for Continuous Operation: All ratings are within the working limits of the motor as recommended by the motor manufacturer. Pump can be operated continuously without damage to the motor.

Sand Handling Design: Our face clearance, floating impeller stack has proven itself for over 40 years as a superior sand handling, durable pump design.

Stainless Steel Metal Parts: AISI types 302, 303 and 304 are corrosion resistant, non-toxic and non-leaching.

FDA Compliant Non-Metallic Parts: Impellers, diffusers and bearing spiders are constructed of glass filled engineered composites. They are corrosion resistant and non-toxic.

Discharge Head: Cast stainless steel discharge head features built-in safety loops and an upthrust limiting stud which is factory set to prevent the rotating assembly from upthrusting. These pumps require a separate field installed external check valve to prevent backflow.

"GS" SERIES MATERIALS OF CONSTRUCTION

Part Name	Material
Discharge Head	AISI 303 SS
Bearing Spider - Upper	Glass Filled Engineered Composite
Bearing	Proprietary Engineered Composite
Klipring	AISI 301 SS
Diffuser	Glass Filled Engineered Composite
Impeller	
Bowl	AISI 304 SS
Intermediate Sleeve*	AISI 304 SS, Powder Metal
Intermediate Shaft Coupling*	AISI 304 SS, Powder Metal
Intermediate Bearing Spider*	Glass Filled Engineered Composite
Intermediate Bearing Spider*	AISI 303 SS
Shim	AISI 304 SS
Screws - Cable Guard	AISI 304 SS
Motor Adapter	AISI 303 SS
Casing	AISI 304 SS
Shaft (up to 3 HP)	
Shaft (5 HP and larger)	
Coupling	AISI 304 SS, Powder Metal
Cable Guard	AISI 304 SS
Suction Screen	AISI 304 SS

* Used on larger models.

Bowls: Stainless steel for strength and abrasive resistance.

Check Valve: Not supplied, order separately, pumps have 2" NPT discharge threads.

Stainless Steel Casing: Polished stainless steel is strong, attractive and corrosion resistant.

Hex Shaft Design: Six sided shafts for positive impeller drive.

Shaft Coupling: Exposed for ease of field alignment to motor shaft and to check pump rotation.

Bearings: Proprietary engineered polymer bearing material is a super strong, abrasion and heat resistant design.

MODELS AND SPECIFICATIONS

Model	Flow Range GPM	HP Range	Best Eff. GPM	Discharge Connection	Minimum Well Size
5GS	1.2 - 7.5	½ - 3	5	2"	4"
7GS	1.5 - 10	½ - 5	7	2"	4"
10GS	3 - 16	1 - 5	10	2"	4"
18GS	6 - 28	1 - 10	18	2"	4"
25GS	8 - 33	1 - 10	25	2"	4"
33GS	10 - 50	1 - 10	33	2"	4"
40GS	20 - 65	1½ - 7½	40	2"	4"
55GS	20 - 80	1½ - 10	55	2"	4"
75GS	40 - 100	3 - 10	75	2"	4"

Rotation on all units is counterclockwise when viewed from pump discharge end.

An optional 4" x 6" Adapter - Part No. **ADAPT46** is available for installations where a 6" motor is desired. The kit contains a 4" x 6" adapter, a 4" to 6" splined shaft extension and required bolts.

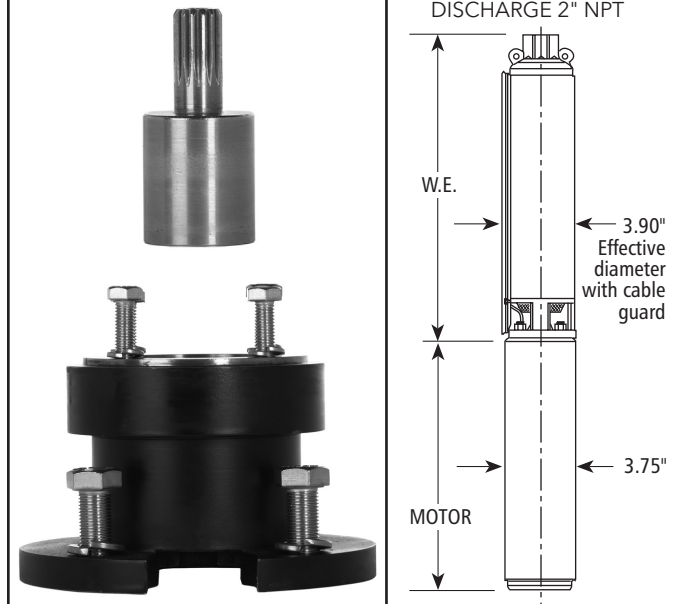

Residential Water Systems

DIMENSIONS AND WEIGHTS

Model	HP	Stages	Length (W.E.)	W.E. Weight (lbs.)
5GS05CBM	½	12	14.8	9
5GS07CBM	¾	15	16.8	10
5GS10CBM	1	20	20.0	12
5GS15CBM	1½	26	25.3	15
5GS20CBM	2	33	30.1	19
5GS30CBM	3	46	42.7	25
7GS05CBM	½	10	13.3	8
7GS07CBM	¾	13	15.4	10
7GS10CBM	1	17	18.3	11
7GS15CBM	1½	22	21.9	13
7GS20CBM	2	27	26.6	16
7GS30CBM	3	34	31.6	20
7GS50CBM	5	54	49.6	28
10GS10CBM	1	12	14.4	10
10GS15CBM	1½	17	17.9	12
10GS20CBM	2	20	20.0	13
10GS30CBM	3	27	26.0	17
10GS50RCBM	5	35	32.5	21
10GS50CBM	5	42	36.3	22
18GS10CBM	1	8	13.0	8
18GS15CBM	1½	11	15.5	10
18GS20CBM	2	14	18.1	11
18GS30CBM	3	19	22.4	13
18GS50RCBM	5	24	27.8	16
18GS50CBM	5	30	33.9	19
18GS75CBM	7½	45	46.7	30
18GS100CBM	10	60	61.7	39

Model	HP	Stages	Length (W.E.)	W.E. Weight (lbs.)
25GS10CBM	1	7	12.8	7
25GS15CBM	1½	9	14.6	9
25GS20CBM	2	11	16.5	10
25GS30CBM	3	15	20.2	12
25GS50RCBM	5	22	28	16
25GS50CBM	5	25	30.9	19
25GS75CBM	7½	34	40.5	24
25GS100CBM	10	50	58.0	31
33GS10CBM	1	6	14.2	9
33GS15CBM	1½	8	16.6	10
33GS20CBM	2	10	19.1	11
33GS30CBM	3	14	24	14
33GS50CBM	5	22	35.1	20
33GS75CBM	7½	34	50.6	28
33GS100CBM	10	44	62.9	34
40GS15CBM	1½	5	13.0	8
40GS20CBM	2	6	14.2	9
40GS30CBM	3	8	16.6	10
40GS50CBM	5	14	24.0	14
40GS75CBM	7½	21	34.0	20
55GS15CBM	1½	5	17.1	10
55GS20CBM	2	7	21.2	13
55GS30CBM	3	9	25.3	16
55GS50CBM	5	15	39.0	23
55GS75CBM	7½	22	54.0	31
55GS100CBM	10	29	68.8	39
75GS30CBM	3	7	24.1	15
75GS50CBM	5	11	34.8	20
75GS75CBM	7½	16	48.2	28
75GS100CBM	10	21	64.0	35

CENTRIPRO 4" SINGLE PHASE MOTORS

Order No.	Type	HP	Volts	Length		Weight	
				In.	MM	Lb.	Kg.
M05421	2-wire PSC	½	115	11.0	279	19.2	8.7
M05422		½	230	11.0	279	19.2	8.7
M07422		¾		12.4	314	22.7	10.3
M10422		1		13.3	337	24.5	11.1
M15422		1½		14.9	378	28.9	13.1
M05411	3-wire	½		115	10.0	253	18.9
M05412		½	230	9.7	246	18.1	8.2
M07412		¾		10.8	275	21.4	9.7
M10412		1		11.7	297	23.1	10.5
M15412		1½		13.6	345	27.4	12.4
M20412		2		15.1	383	31.0	14.1
M30412		3		18.3	466	40.0	18.1
M50412		5		27.7	703	70.0	31.8

CENTRIPRO 4" THREE PHASE MOTORS

Order No.	HP	Volts	Length		Weight	
			In.	MM	Lb.	Kg.
M05430	½	200	10.8	275	22	9.7
M07430	¾		10.8	275	22	9.7
M10430	1		11.7	297	23.1	10.5
M15430	1½		11.7	297	23.1	10.5
M20430	2		13.8	351	27.4	12.4
M30430	3		15.3	389	32	14.5
M50430	5		21.7	550	55	24.9
M75430	7½		27.7	703	70	31.8
M05432	½		230	10.8	275	22
M07432	¾	10.8		275	22	9.7
M10432	1	11.7		297	23.1	10.5
M15432	1½	11.7		297	23.1	10.5
M20432	2	13.8		351	27.4	12.4
M30432	3	15.3		389	32	14.5
M50432	5	21.7		550	55	24.9
M75432	7½	27.7		703	70	31.8
M05434	½	460		10.8	275	22
M07434	¾		10.8	275	22	9.7
M10434	1		11.7	297	23.1	10.5
M15434	1½		11.7	297	23.1	10.5
M20434	2		13.8	351	27.4	12.4
M30434	3		15.3	389	32	14.5
M50434	5		21.7	550	55	24.9
M75434	7½		27.7	703	70	31.8
M100434	10		30.7	780	78	35.4

ORDER NUMBER CODE

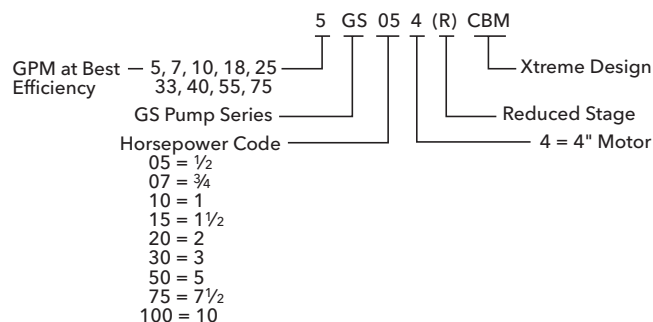

5GSCBM Curve

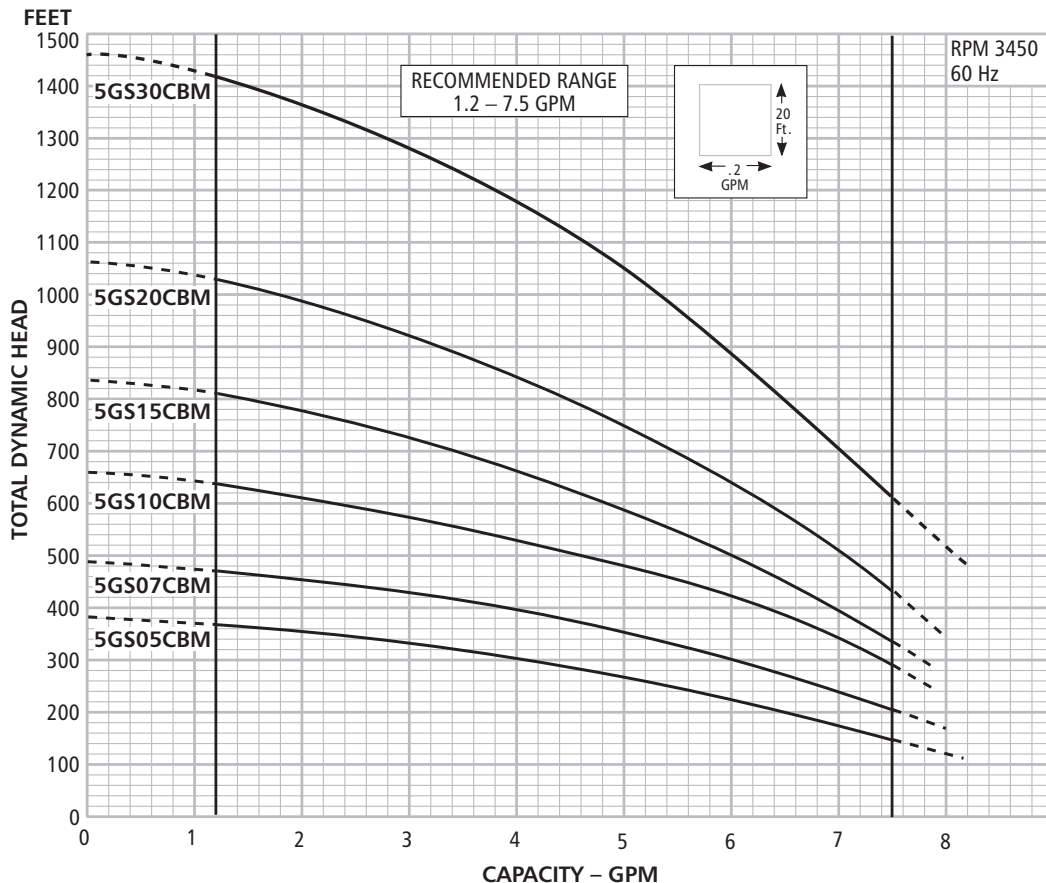

7GSCBM Curve

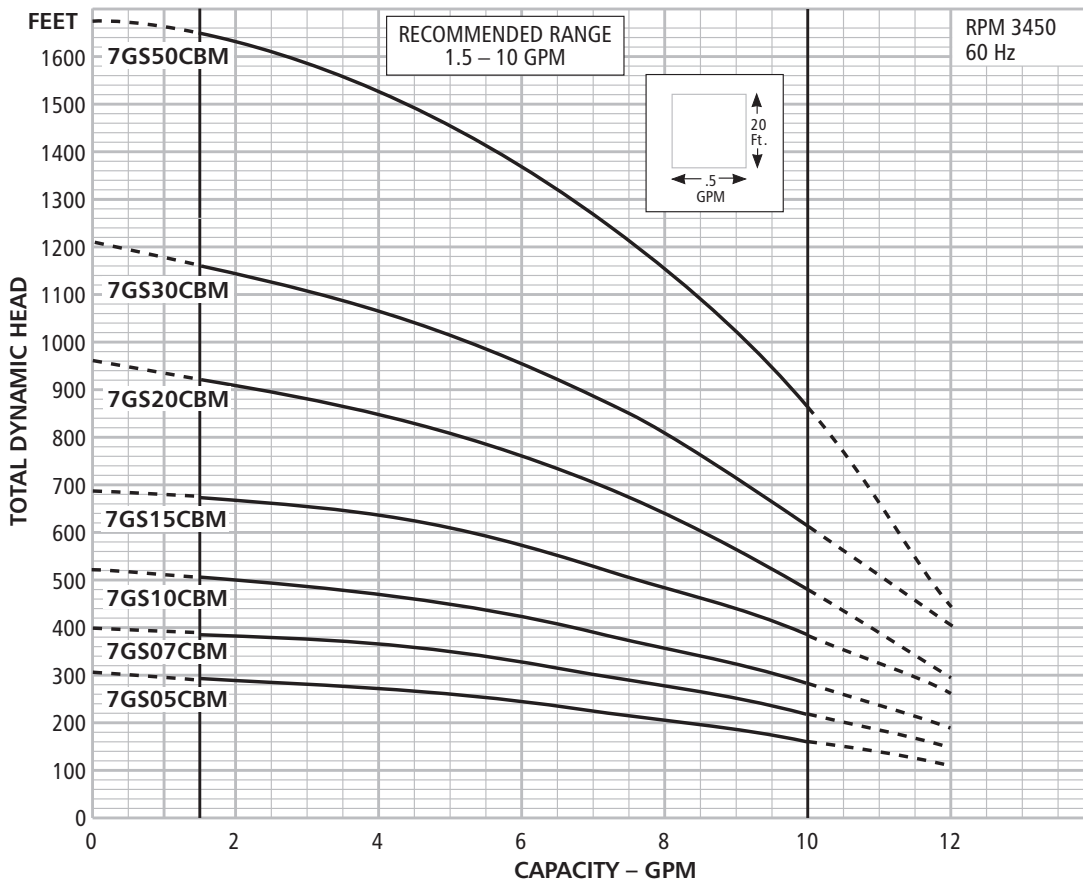

10GSCBM Curve

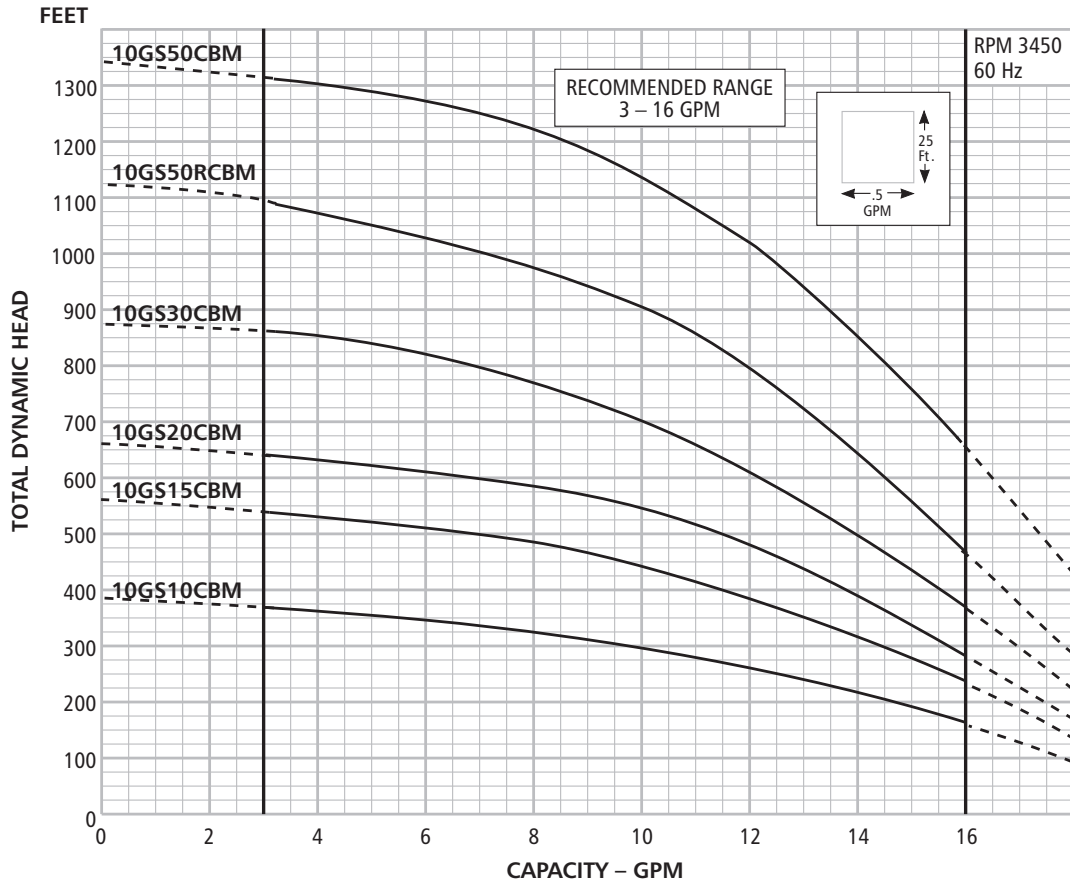

18GSCBM Curve

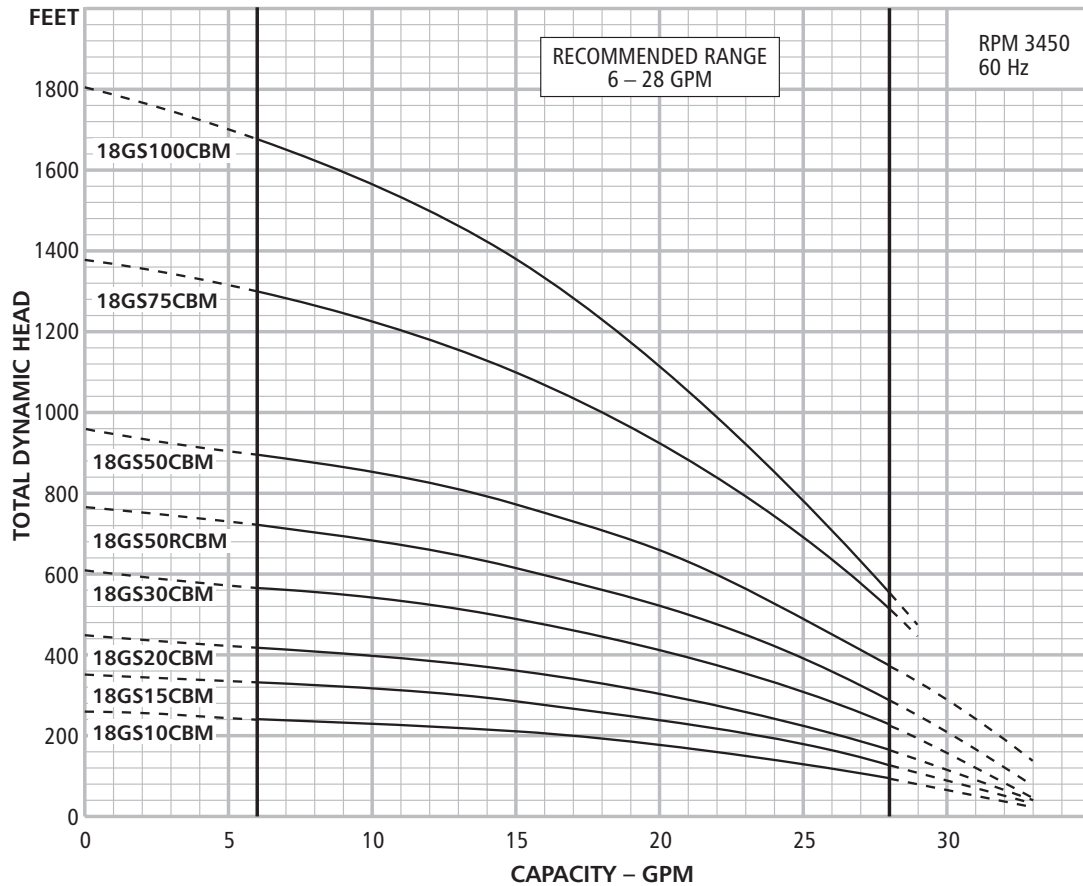

25GSCBM Curve

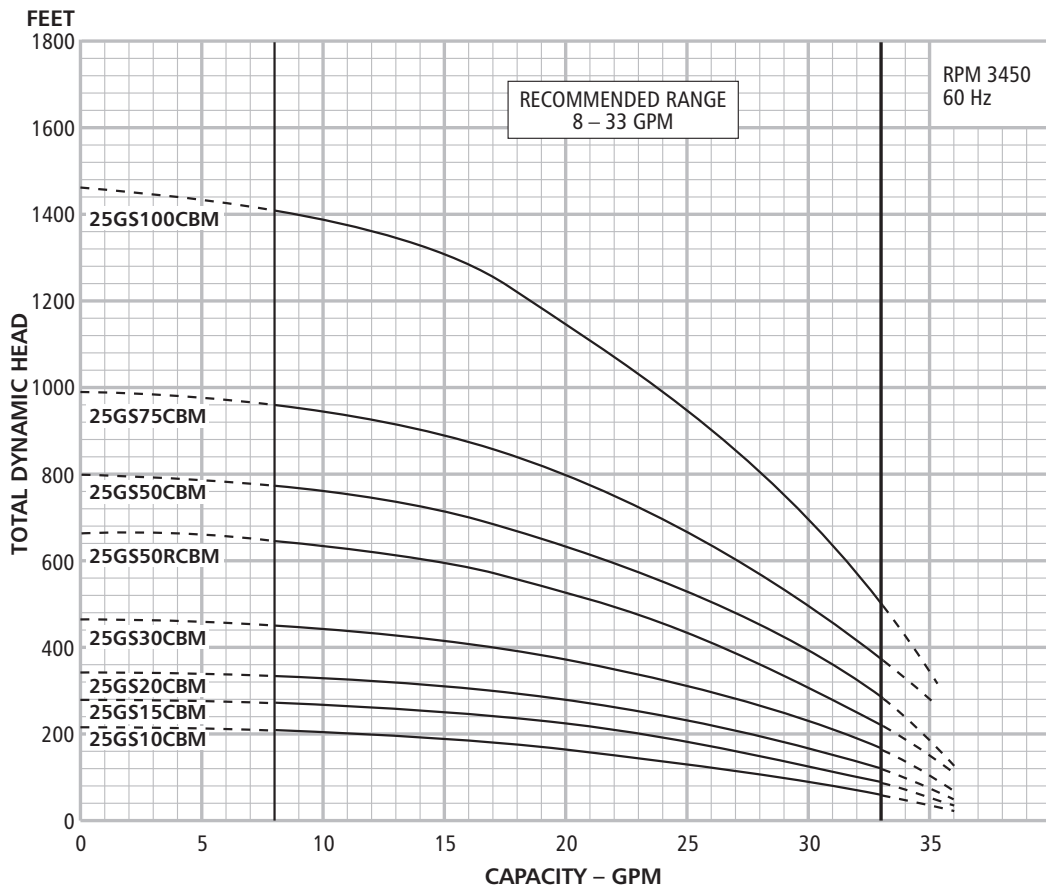

33GSCBM Curve

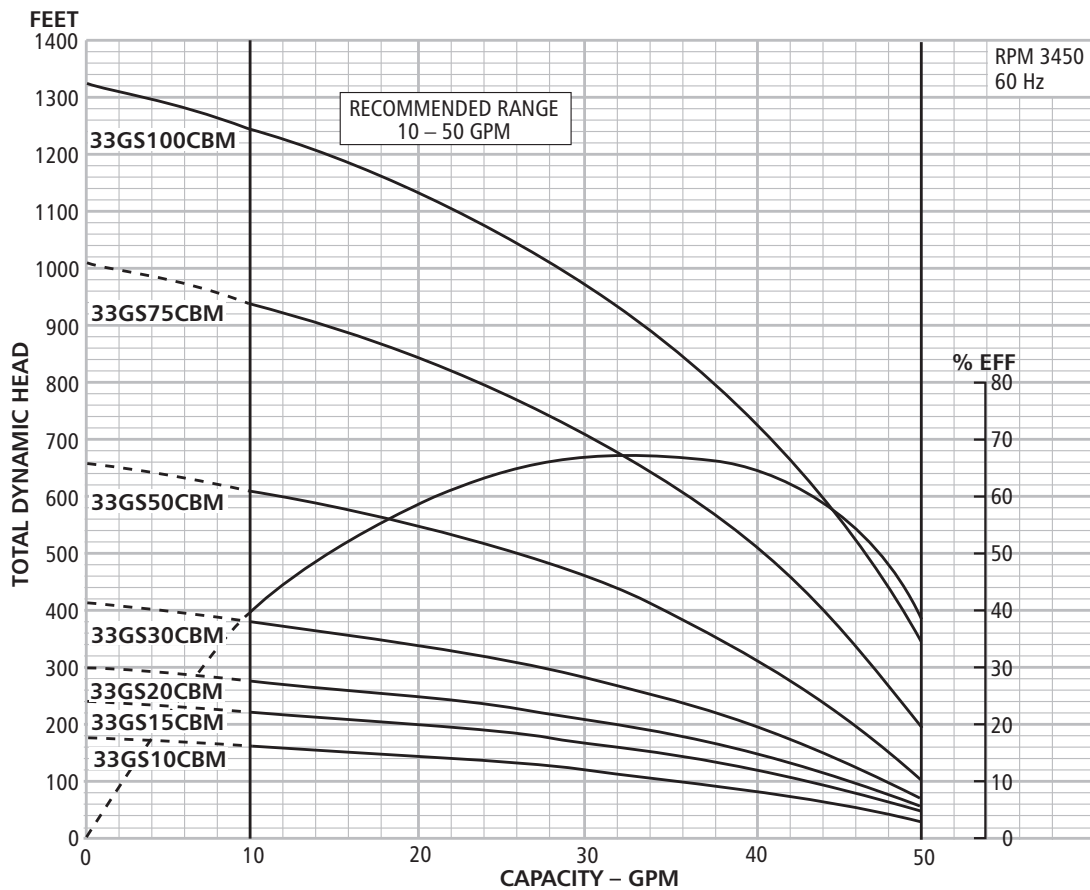

40GSCBM Curve

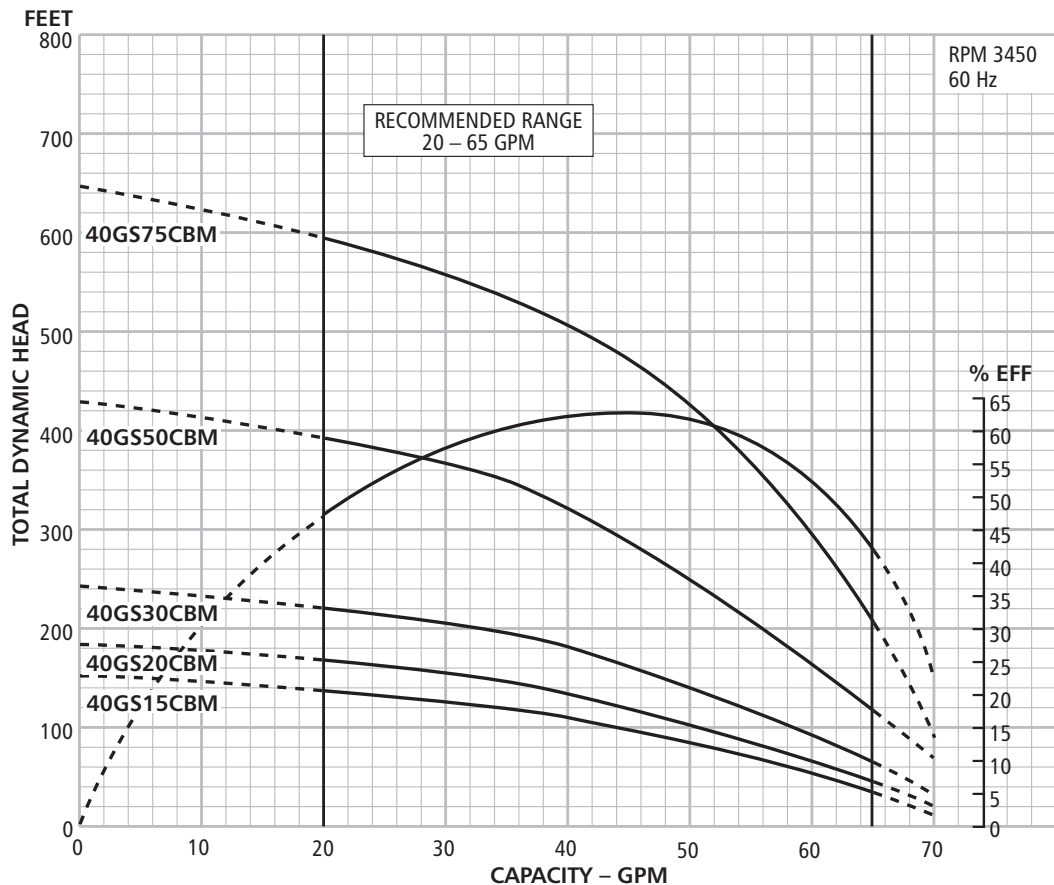

55GSCBM Curve

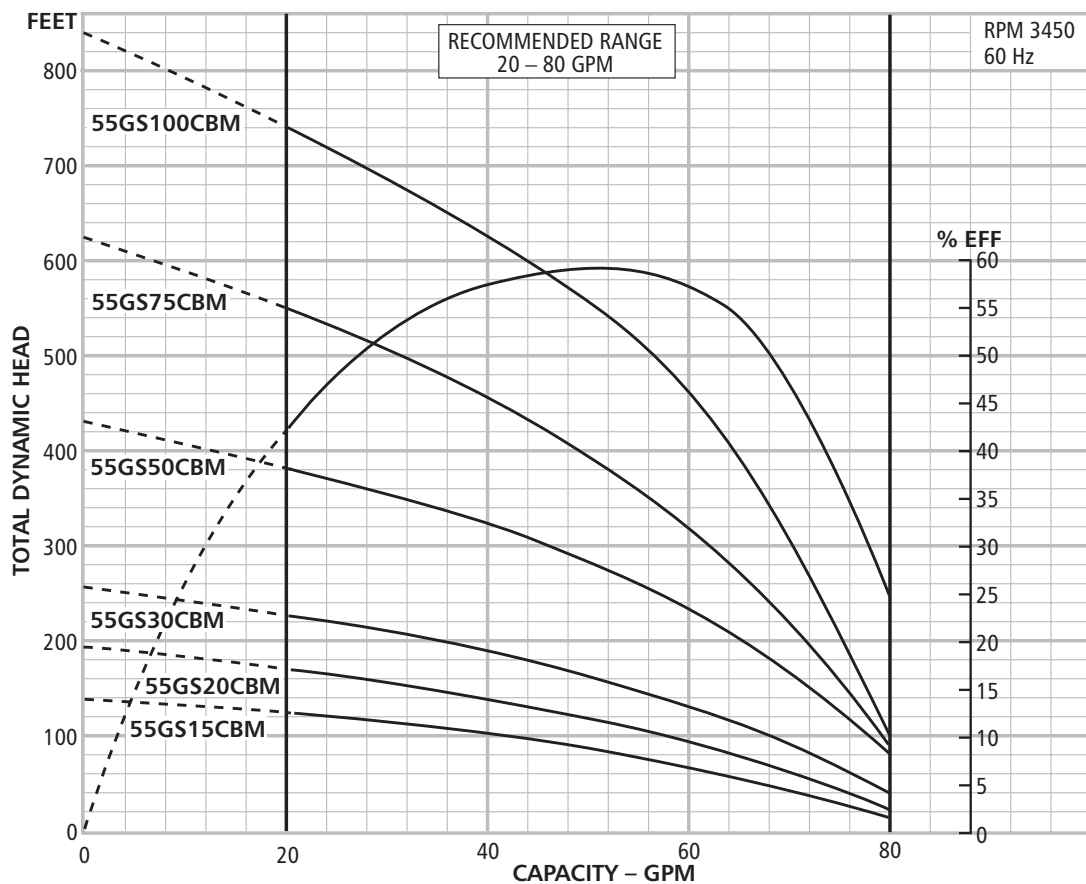

75GSCBM Curve

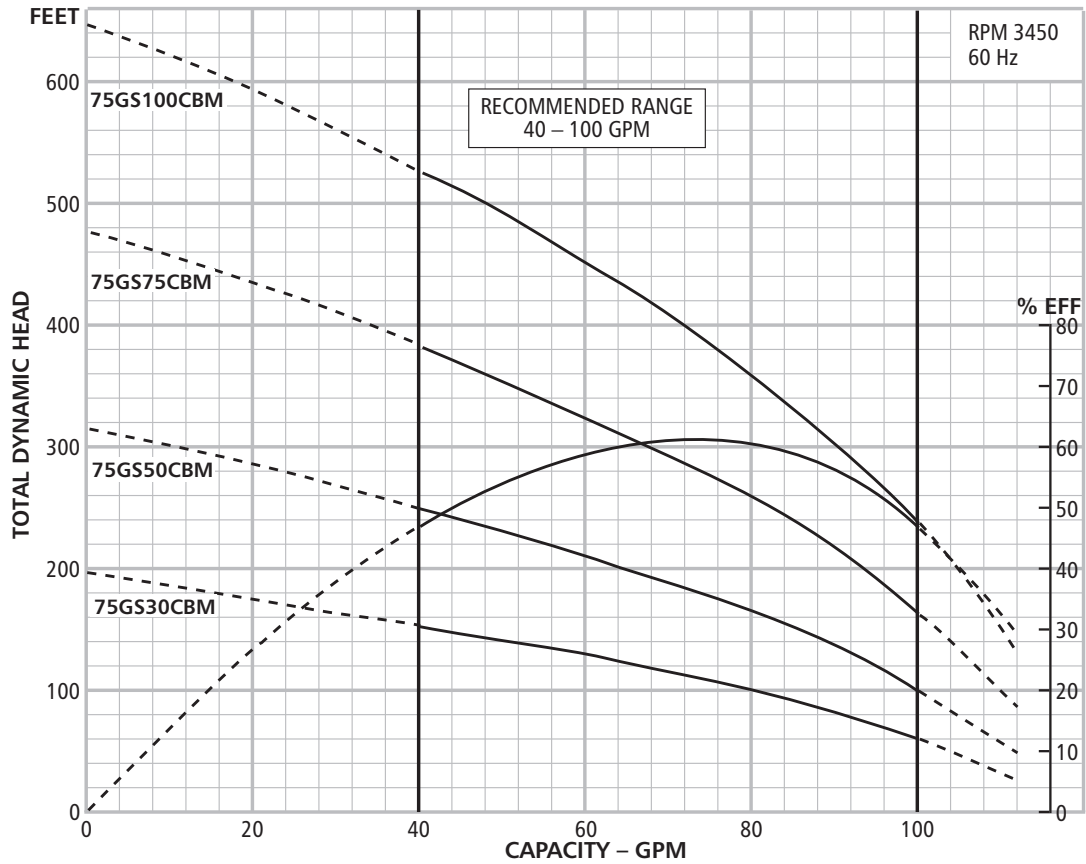

Xylem, Inc.
 2881 East Bayard Street Ext., Suite A
 Seneca Falls, NY 13148
 Phone: (866) 325-4210
 Fax: (888) 322-5877

www.xyleminc.com/brands/gouldswatertechnology

Goulds is a registered trademark of Goulds Pumps, Inc. and is used under license.
 GS Xtreme is a trademark of Xylem Inc. or one of its subsidiaries.

© 2012 Xylem Inc. B5-75GSX April 2012